

CANTUS

Sofisticiran i potpuno u boji.

- Ujednačeni crep sa kontinuiranom lepotom boje zahvaljujući najfinijim sirovinama "KERALIS" i pažljivoj obradi. Na odrezanim rubovima ili kod oštećenja nisu potrebni dodatni radovi.
- Izuzetna fleksibilnost i pojednostavljeno postavljanje zahvaljujući velikom pomičnom području od 38 mm
- Sofisticirana tehnologija preklapanja omogućava efikasnu drenažu vode i zaštitu od prodora kiše
- Najviši nivo kvaliteta garantuje se najboljim sirovinama i savremenim postupkom beskontaktnog pečenja u ravnoj kaseti za pečenje, kao i neprekidnom optimizacijom procesa proizvodnje

TEHNIČKI PODACI

Dimenzije (pribl.)	265 x 450 mm
Min. pokrivna širina pribl.	222 mm
Pros. pokrivna širina pribl.	223 mm
Maks. pokrivna širina (pribl.)	224 mm
Min. letvanje (pribl.)	348 mm
Pros. pokrivna dužina pribl.	366 mm
Maks. letvanje (pribl.)	384 mm
Min. potreban crep (pribl.)	11.8 kom./m ²
Prosečno potreban crep (pribl.)	12.3 kom./m ²
Cigle, maks. pribl.	12.9 kom./m ²
Jedinična težina (pribl.)	3.55 kg/komad
Težina po m ² (pribl.)	44.4 kg/m ²
Težina po paleti (pribl.)	877 kg
Komada po mini pakovanju	5 komad
Kom. po paleti	240 komad



LAF-/FLA VREDNOSTI

LAF-/FLA VREDNOSTI U MM SA FALCOM ZA 30X50 LETVE												
potreban grebeni crep (pribl.)	DN	10°	15°	20°	25°	30°	35°	40°	45°	50°	55°	60°
PHP 2.6 pak/m	LAF	60	55	55	50	40	35	30	20	15	10	
PHP 2.6 pak/m	FLA	110	105	95	90	85	80	75	70	65	60	
PP 2.5 pak/m	LAF	70	65	60	55	50	45	40	35	35	30	20
PP 2.5 pak/m	FLA	105	100	90	85	80	70	65	60	50	45	45

LAF-/FLA VREDNOSTI U MM SA FALCOM ZA 40X60 LETVE												
potreban grebeni crep (pribl.)	DN	10°	15°	20°	25°	30°	35°	40°	45°	50°	55°	60°
PHP 2.6 pak/m	LAF	60	55	55	45	35	30	25	10	5		
PHP 2.6 pak/m	FLA	120	115	105	100	95	90	85	80	75		
PP 2.5 pak/m	LAF	70	65	60	50	45	40	35	25	20	15	5
PP 2.5 pak/m	FLA	115	110	100	95	90	80	75	70	60	55	55



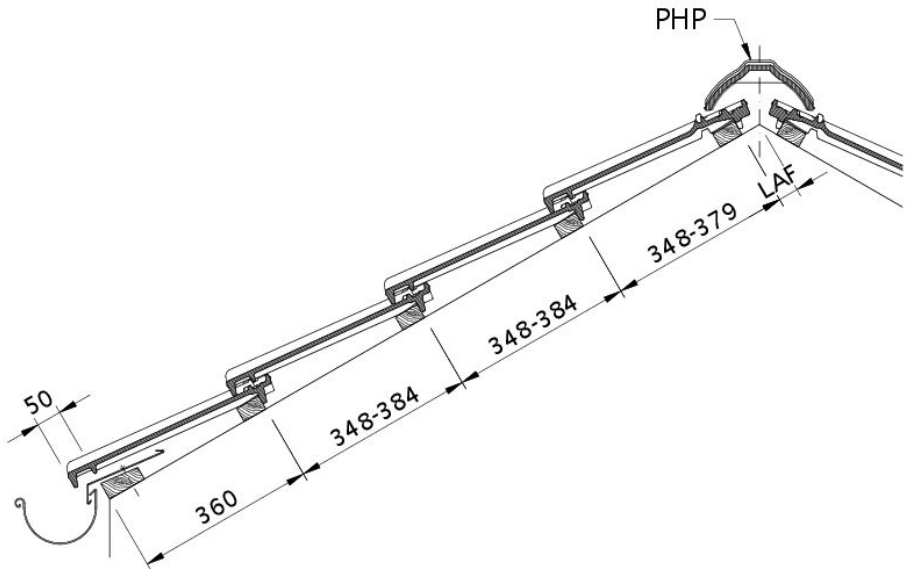

Tehnički crtež proizvoda CANTUS DQF DQF

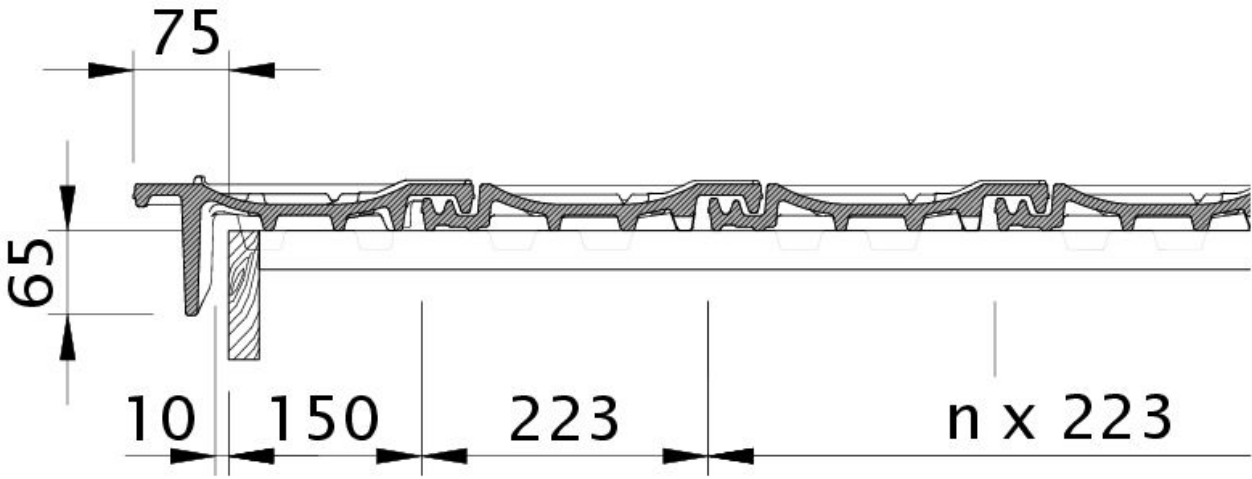

Tehnički crtež proizvoda CANTUS OBL OBL



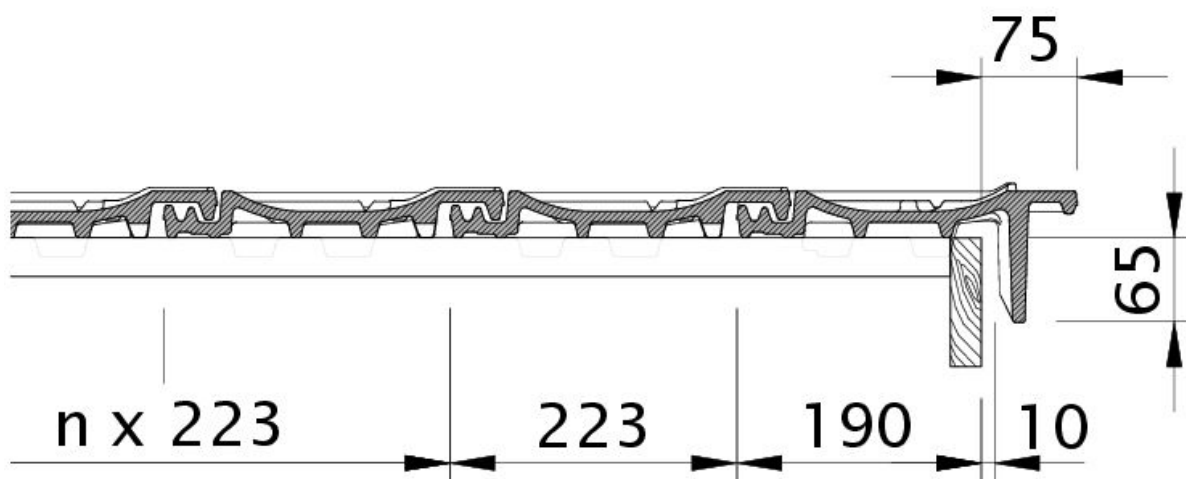

Tehnički crtež proizvoda CANTUS OBR OBR

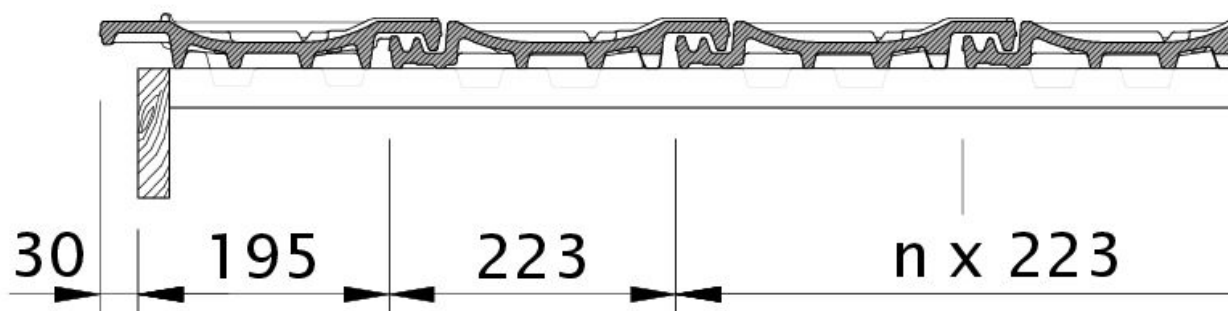

Tehnički crtež proizvoda CANTUS OG levi sa ivičnim limom i duplim pokrivanjem ODL



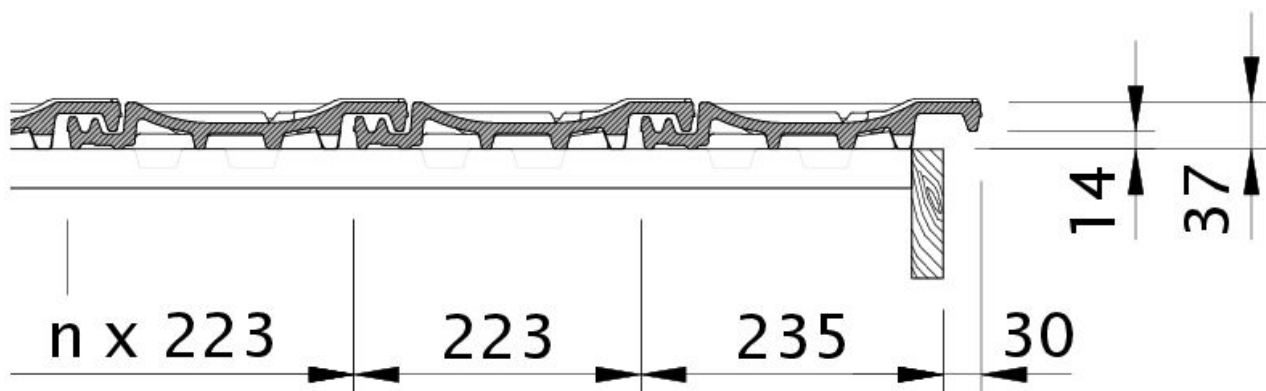

Tehnički crtež proizvoda CANTUS OG desni sa ivičnim limom i osnovnim crepom OFR

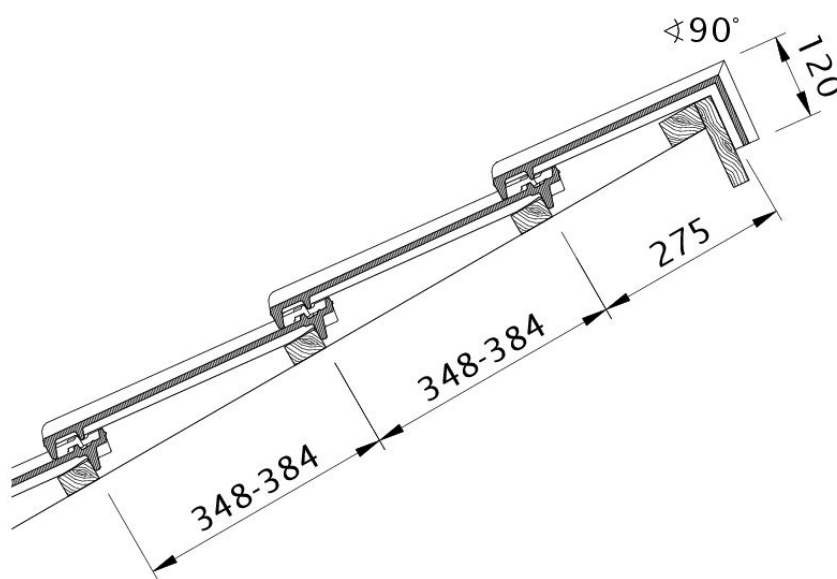

Tehnički crtež proizvoda CANTUS PDA PDA



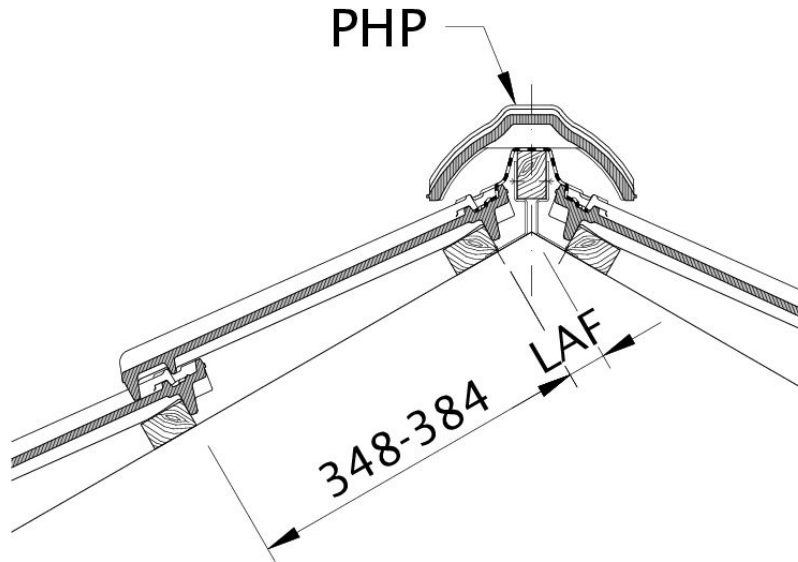

Zeichnung CANTUS Lattenabstand zum Firstschnittpunkt, Firstlattenabstand LAF

