

RATIO

Ekonomičan veliki falcovani crep.

- Veliki format (265 x 446 mm) čini ovaj crep izuzetno ekonomičnim
- Fleksibilan gabarit za brzu ugradnju, zahvaljujući opsegu podešavanja od 24 mm
- Tolerancija podešavanja od 5 mm za dodatnu fleksibilnost
- Široka paleta boja: 11 boja i četiri varijacije površina
- Harmoničan dizajn inspirisan tradicionalnim modelom Z1 koji je kreirao Ludovici
- Kanal za vodu na strani crepa uklanja pritisak sa bočnog preklapanja da bi se obezbedila nesmetana drenaža vode

TEHNIČKI PODACI

Dimenzije (pribl.)	265 x 446 mm
Min. pokrivna širina pribl.	221 mm
Pros. pokrivna širina pribl.	223 mm
Maks. pokrivna širina (pribl.)	225 mm
Min. letvanje (pribl.)	357 mm
Pros. pokrivna dužina pribl.	368 mm
Maks. letvanje (pribl.)	380 mm
Min. potreban crep (pribl.)	11.7 kom./m ²
Prosečno potreban crep (pribl.)	12.2 kom./m ²
Cigle, maks. pribl.	12.7 kom./m ²
Jedinična težina (pribl.)	3.3 kg/komad
Težina po m ² (pribl.)	40.3 kg/m ²
Težina po paleti (pribl.)	975 kg
Komada po mini pakovanju	6 komad
Kom. po paleti	288 komad



LAF-/FLA VREDNOSTI

LAF-/FLA VREDNOSTI U MM SA FALCOM ZA 30X50 LETVE									
potreban grebeni crep (pribl.)	DN	15°	20°	25°	30°	35°	40°	45°	50°
PH 2.6 pak/m	LAF	60	55	50	50	45	45	40	30
PH 2.6 pak/m	FLA	95	80	75	70	65	55	55	55

LAF-/FLA VREDNOSTI U MM SA FALCOM ZA 40X60 LETVE									
potreban grebeni crep (pribl.)	DN	15°	20°	25°	30°	35°	40°	45°	50°
PH 2.6 pak/m	LAF	60	55	45	45	40	40	30	15
PH 2.6 pak/m	FLA	105	90	85	80	75	65	65	65

LAF-/FLA VREDNOSTI U MM SA FALCOM ZA 50X50 LETVE									
potreban grebeni crep (pribl.)	DN	15°	20°	25°	30°	35°	40°	45°	50°
PH 2.6 pak/m	LAF	55	50	40	40	30	30	20	5
PH 2.6 pak/m	FLA	115	100	95	90	90	80	80	85



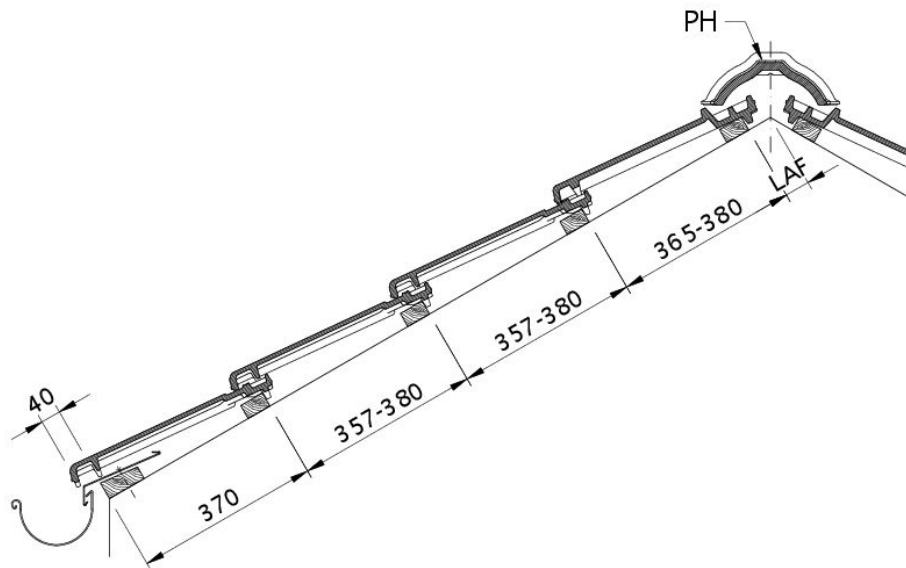

Tehnički crtež proizvoda RATIO DQF DQF

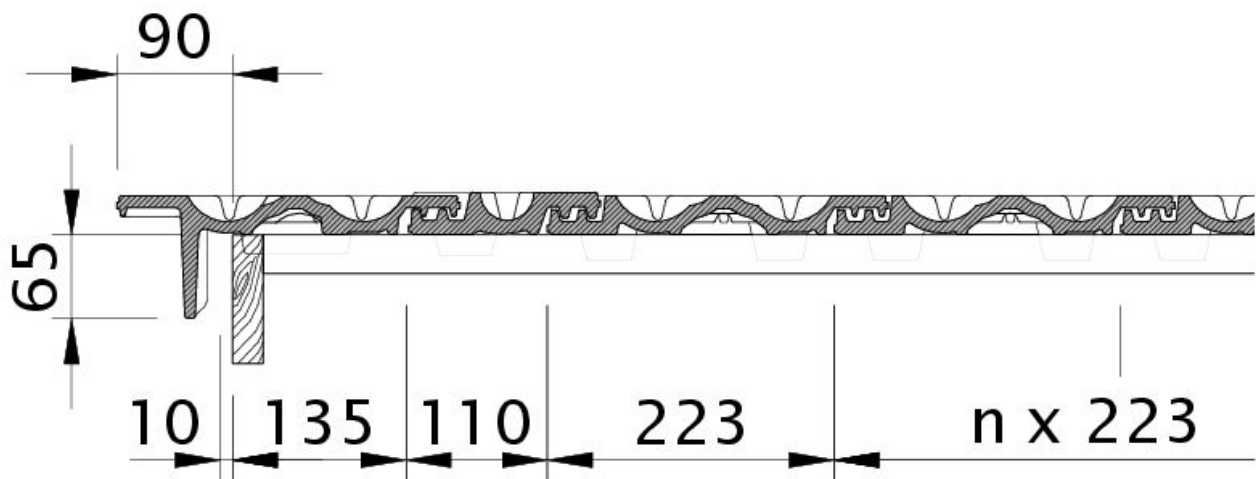

Tehnički crtež proizvoda RATIO OBL OBL



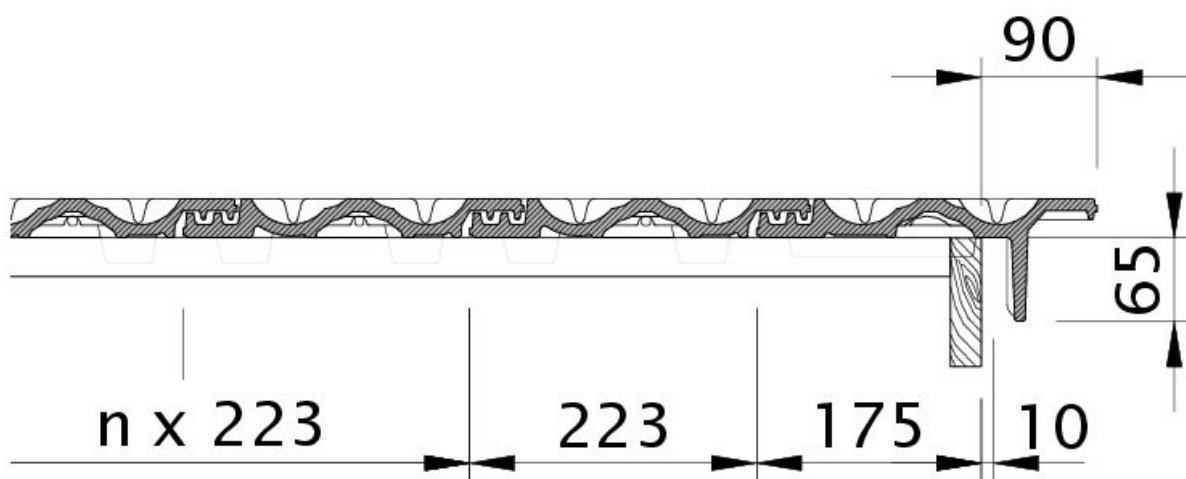

Tehnički crtež proizvoda RATIO OBR OBR

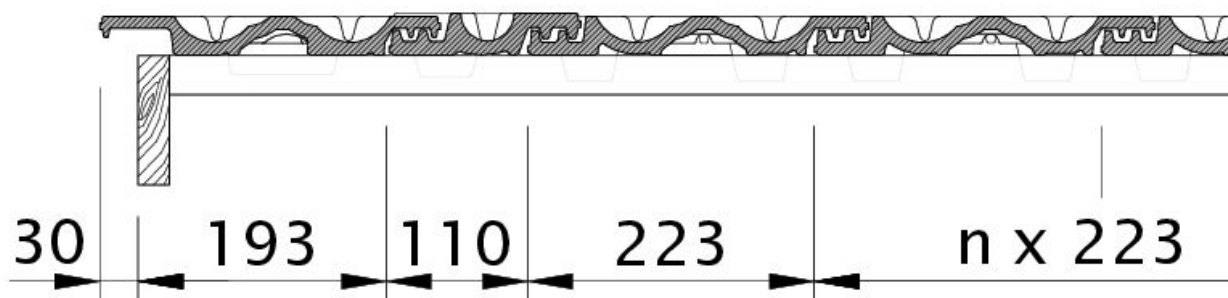

Tehnički crtež proizvoda RATIO OG levi sa ivičnim limom i duplim pokrivanjem ODL



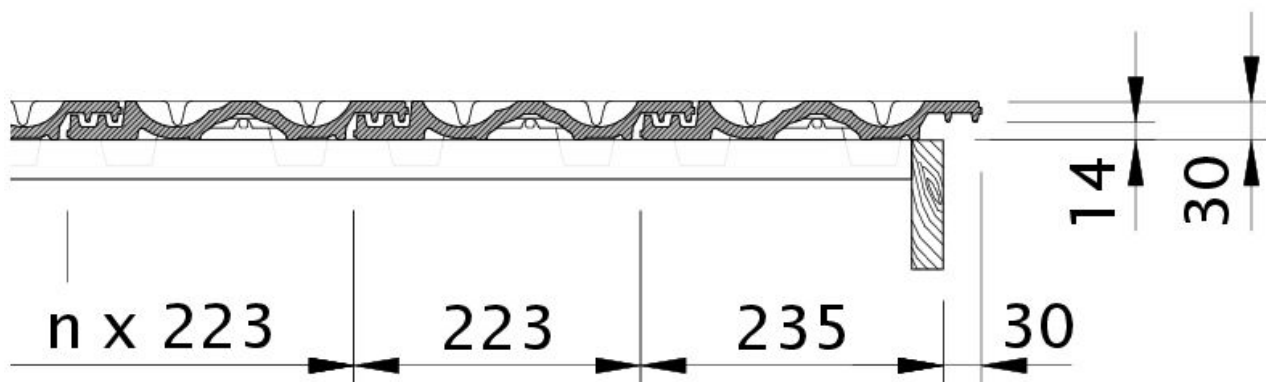

Tehnički crtež proizvoda RATIO OG desni sa ivičnim limom i osnovnim crepom OFR

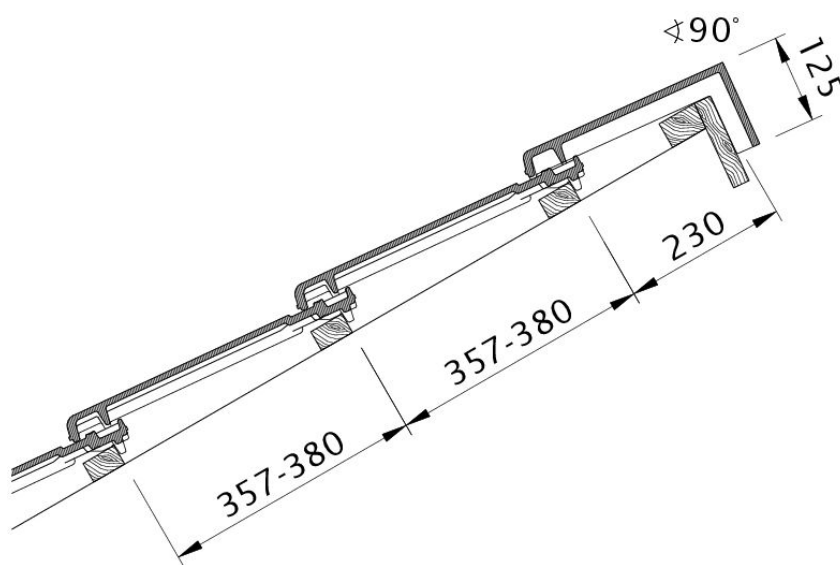

Tehnički crtež proizvoda RATIO PDA PDA



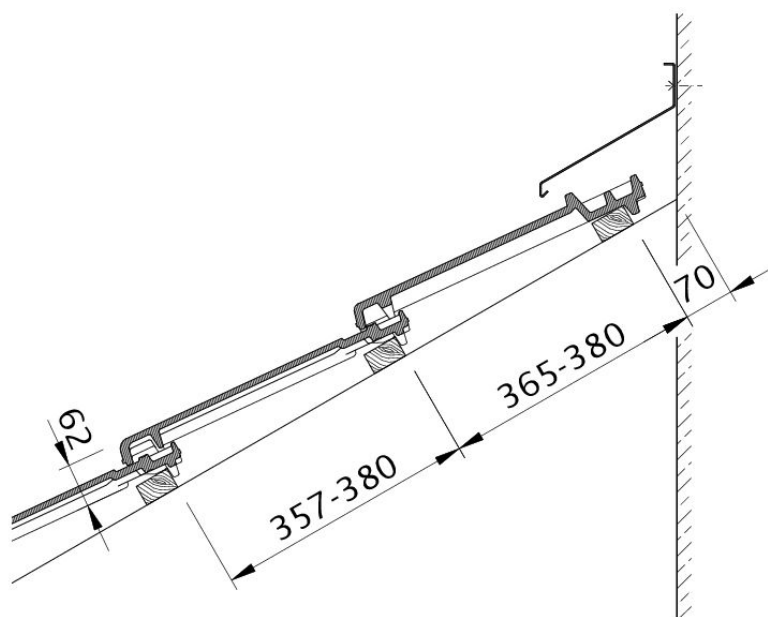

Tehnički crtež proizvoda RATIO WMF WMF

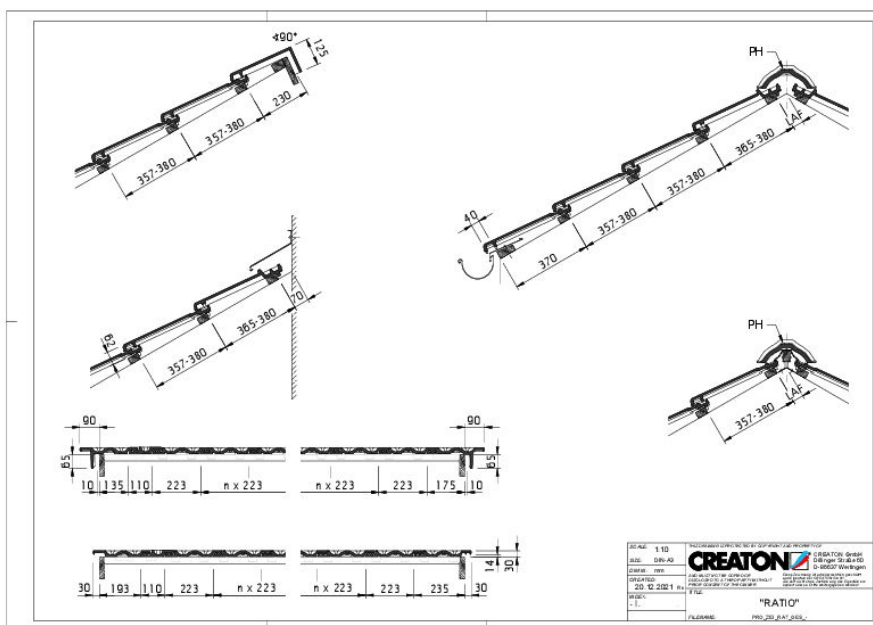

Drawing RATIO general view GES



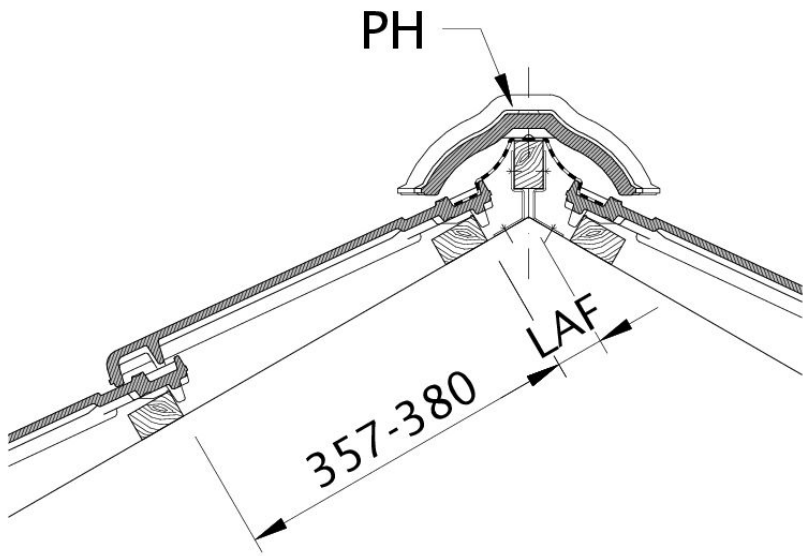

Drawing RATIO distance from batten to ridge intersection point, ridge batten spacing LAF

