

MZ3

Unapređeni klasik.

- Naglašena bočna rebra sprečavaju prodor vode čak i pri jakim udarima vetra
- Pomično područje od 28 mm za optimalno prilagođavanje širini letvica
- Efikasno odvođenje vode i optimalne karakteristike protoka, zahvaljujući tehnički savršenom preklapanju
- Izvrsne sirovine osiguravaju glatku površinu crepa
- Dvostruka rebra u podnožju osiguravaju sigurno prijanjanje i smanjuju prodor snega ili kiše koju nanosi vetar
- Bolja drenaža vode zahvaljujući optimiziranim žlebovima u gornjem delu

TEHNIČKI PODACI

Dimenzije (pribl.)	268 x 442 mm
Min. pokrivna širina pribl.	216 mm
Pros. pokrivna širina pribl.	218 mm
Maks. pokrivna širina (pribl.)	220 mm
Min. letvanje (pribl.)	334 mm
Pros. pokrivna dužina pribl.	345 mm
Maks. letvanje (pribl.)	360 mm
Min. potreban crep (pribl.)	12.6 kom./m ²
Prosečno potreban crep (pribl.)	13.3 kom./m ²
Cigle, maks. pribl.	13.9 kom./m ²
Jedinična težina (pribl.)	3.6 kg/komad
Težina po m ² (pribl.)	47.9 kg/m ²
Težina po paleti (pribl.)	889 kg
Komada po mini pakovanju	5 komad
Kom. po paleti	240 komad



LAF-/FLA VREDNOSTI

LAF-/FLA VREDNOSTI U MM SA FALCOM ZA 30X50 LETVE											
potreban grebeni crep (pribl.)	DN	10°	15°	20°	25°	30°	35°	40°	45°	50°	55°
PMZ 2.6 pak/m	LAF	65	60	55	50	45	40	35	25	15	10
PMZ 2.6 pak/m	FLA	125	120	115	105	100	95	95	90	90	85

LAF-/FLA VREDNOSTI U MM SA FALCOM ZA 40X60 LETVE											
potreban grebeni crep (pribl.)	DN	10°	15°	20°	25°	30°	35°	40°	45°	50°	
PMZ 2.6 pak/m	LAF	65	60	55	45	40	35	30	15	5	
PMZ 2.6 pak/m	FLA	135	130	125	115	110	105	105	100	100	

LAF-/FLA VREDNOSTI U MM SA FALCOM ZA 50X50 LETVE											
potreban grebeni crep (pribl.)	DN	10°	15°	20°	25°	30°	35°	40°	45°		
PMZ 2.6 pak/m	LAF	60	55	50	40	35	25	20	5		
PMZ 2.6 pak/m	FLA	145	140	135	125	120	120	120	115		



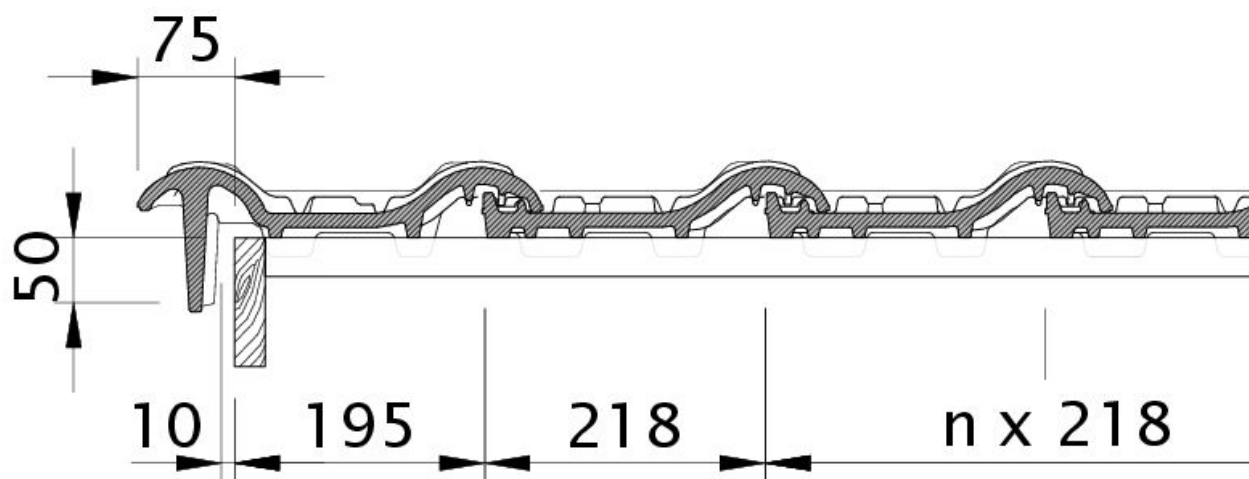

Tehnički crtež proizvoda MZ3 OBL OBL

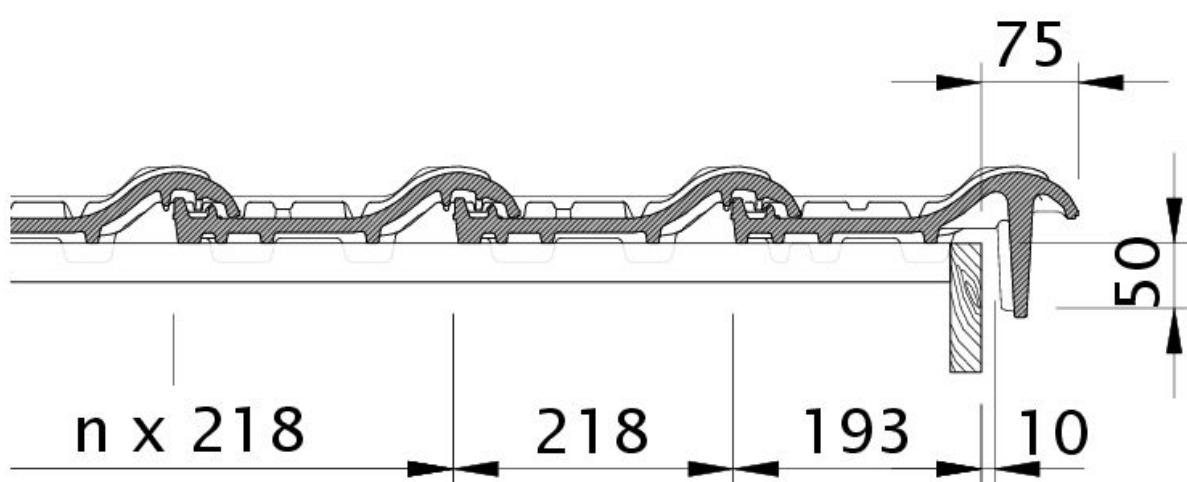

Tehnički crtež proizvoda MZ3 OBR OBR



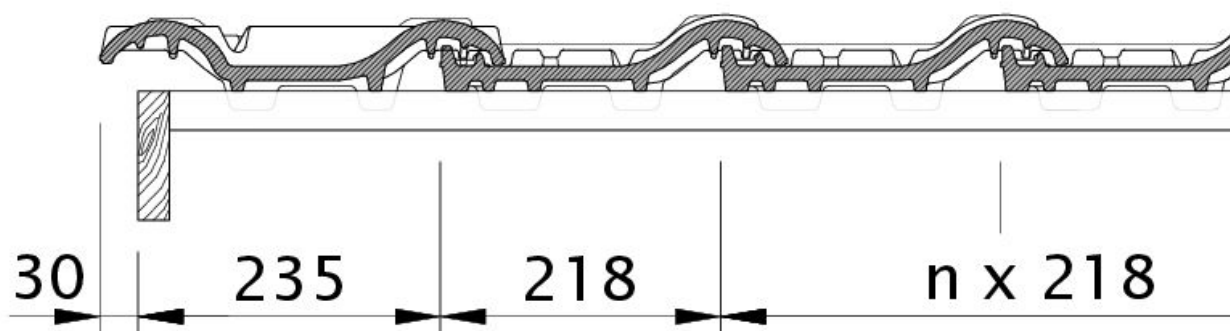

Tehnički crtež proizvoda MZ3 OG levi sa ivičnim limom i duplim pokrivanjem ODL

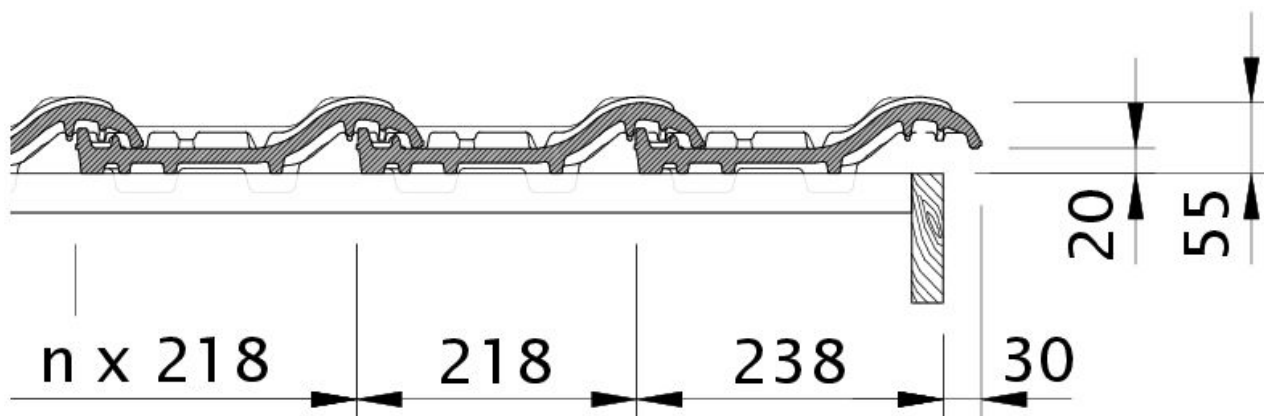

Tehnički crtež proizvoda MZ3 OG desni sa ivičnim limom i osnovnim crepom OFR



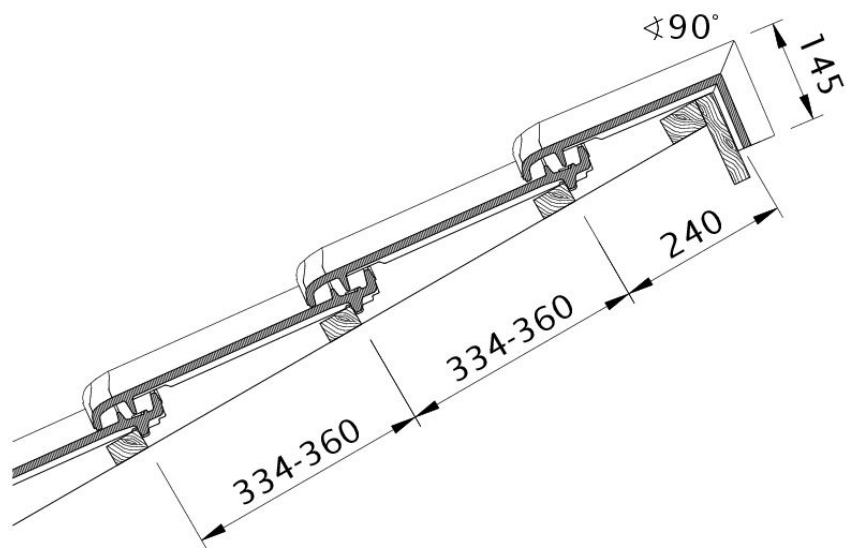

Tehnički crtež proizvoda MZ3 DQF PDA

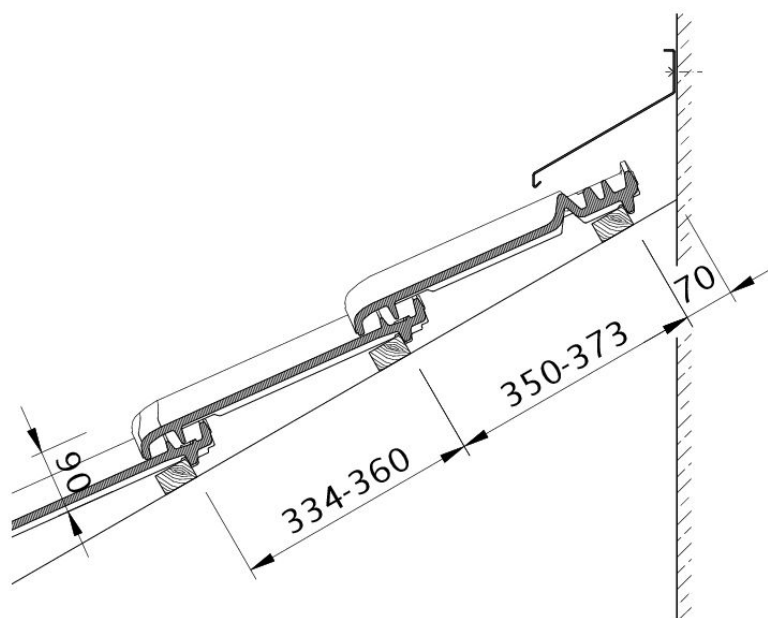

Tehnički crtež proizvoda MZ3 WMF WMF



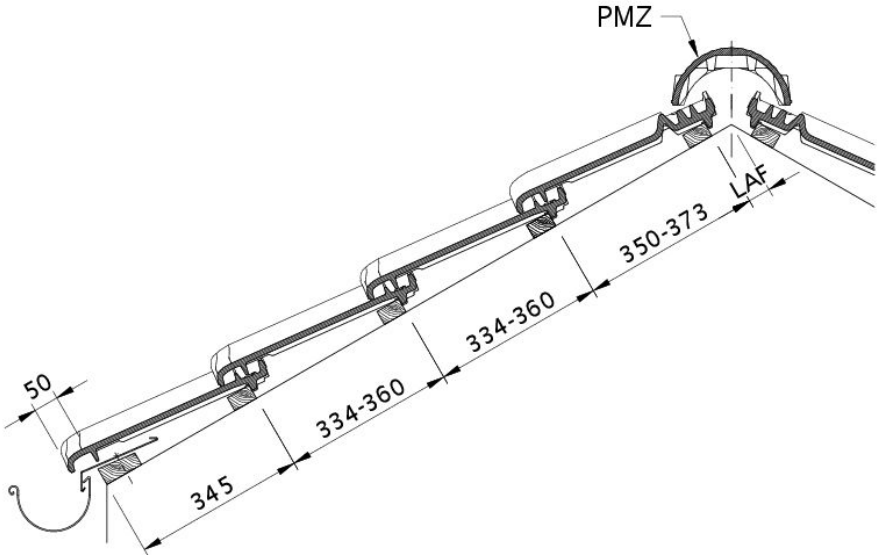

Tehnički crtež proizvoda MZ3 DQF DQF

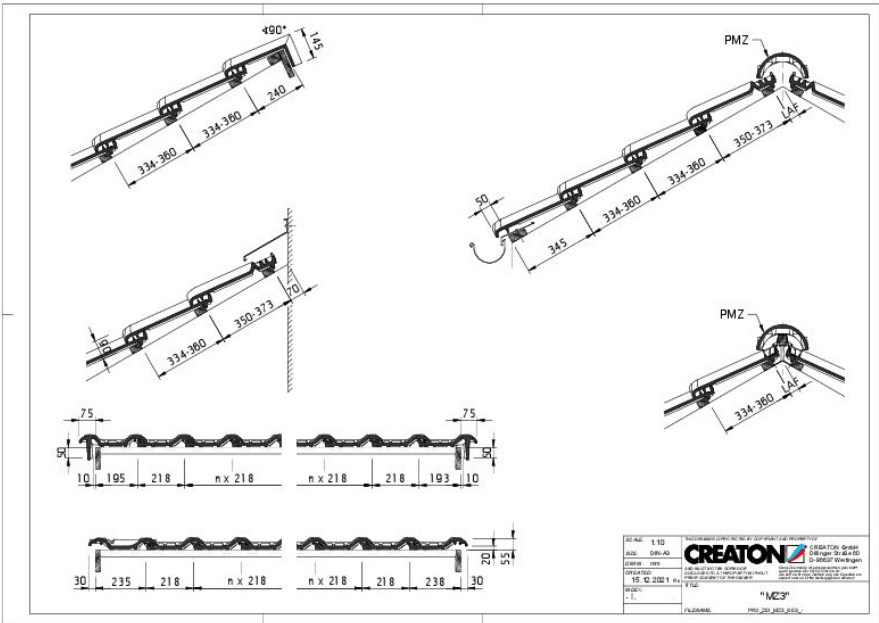

Drawing MZ3 NEU general view GES



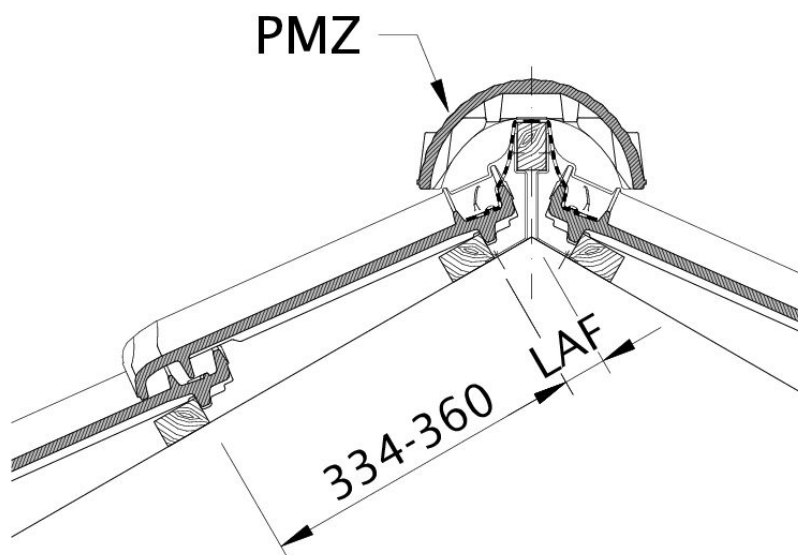

Tehnički crtež proizvoda MZ3 LAF LAF

