

DOMINO

Linearno elegantan crep.

- Veliko pomično područje od 12 mm po crepu
- Prvoklasne sirovine omogućavaju visok stepen homogenosti, malo skupljanje, a visok udeo gvožđe-oksida stvara prirodne, blistavo intenzivne boje
- Veoma izražen oblik udubljenja na vertikalnom preklopu
- Prema smernicama Centralnog udruženja nemačke krovopokrivačke delatnosti (ZVDH), kod sporednih zgrada pri prekrivanju sa spajanjem, mogu se postavljati na krovove sa nagibom od 25° i većim bez dodatnih mera.
- DOMINO ima jedan vertikalni preklop. Ali, kako! Veoma izražen oblik udubljenja omogućava optimalnu kontrolu vode, čak i u najžešćim olujama. Stepnasti preklopi pouzdano štite od prodiranja vode i prljavštine

TEHNIČKI PODACI

Dimenzije (pribl.)	257 x 436 mm
Min. pokrивna širina pribl.	224 mm
Pros. pokrивna širina pribl.	225 mm
Maks. pokrивna širina (pribl.)	226 mm
Min. letvanje (pribl.)	343 mm
Pros. pokrивna dužina pribl.	348 mm
Maks. letvanje (pribl.)	354 mm
Min. potreban crep (pribl.)	12,4 kom./m ²
Prosečno potreban crep (pribl.)	12,7 kom./m ²
Cigle, maks. pribl.	13,1 kom./m ²
Jedinična težina (pribl.)	4,2 kg/komad
Težina po m ² (pribl.)	53,3 kg/m ²
Težina po paleti (pribl.)	1033 kg
Komada po mini pakovanju	4 komad
Kom. po paleti	240 komad



LAF-/FLA VREDNOSTI

LAF-/FLA VREDNOSTI U MM SA FALCOM ZA 30X50 LETVE										
potreban grebeni crep (pribl.)	DN	15°	20°	25°	30°	35°	40°	45°	50°	55°
PD 2.5 pak/m	LAF	95	90	85	85	85	85	85	85	85
PD 2.5 pak/m	FLA	85	80	70	60	50	40	30	25	15

LAF-/FLA VREDNOSTI U MM SA FALCOM ZA 40X60 LETVE										
potreban grebeni crep (pribl.)	DN	15°	20°	25°	30°	35°	40°	45°	50°	55°
PD 2.5 pak/m	LAF	95	90	80	80	80	80	75	70	70
PD 2.5 pak/m	FLA	95	90	80	70	60	50	40	35	25

LAF-/FLA VREDNOSTI U MM SA FALCOM ZA 50X50 LETVE										
potreban grebeni crep (pribl.)	DN	15°	20°	25°	30°	35°	40°	45°	50°	55°
PD 2.5 pak/m	LAF	90	85	75	75	70	70	65	60	60
PD 2.5 pak/m	FLA	105	100	90	80	75	65	55	55	45

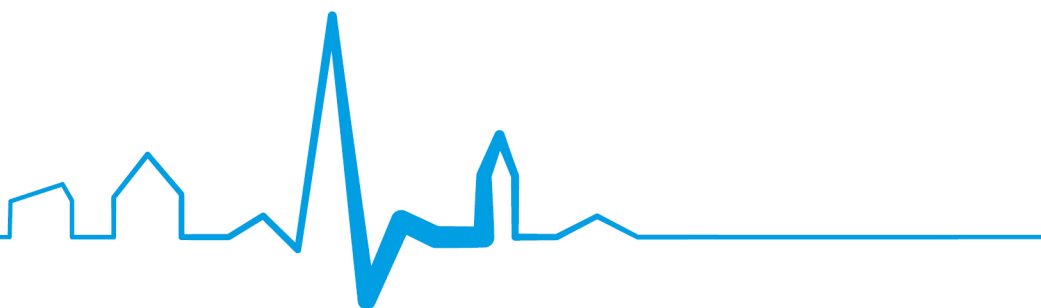

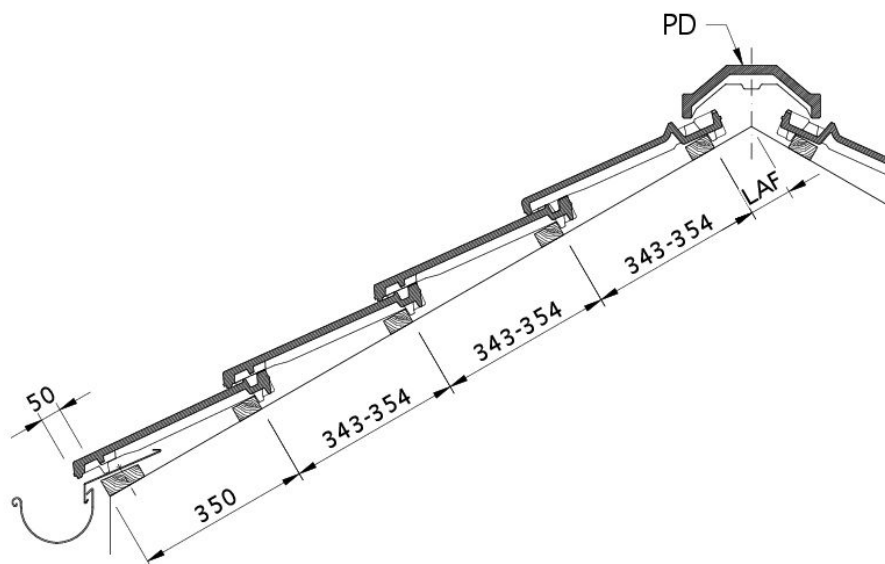

Tehnički crtež proizvoda DOMINO DQF DQF

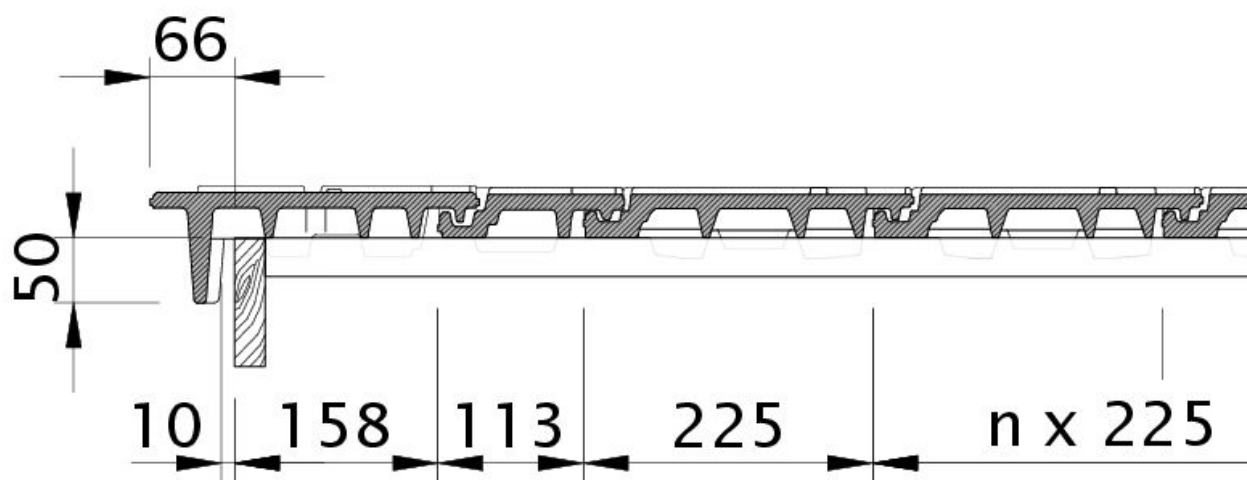

Tehnički crtež proizvoda DOMINO OBL OBL



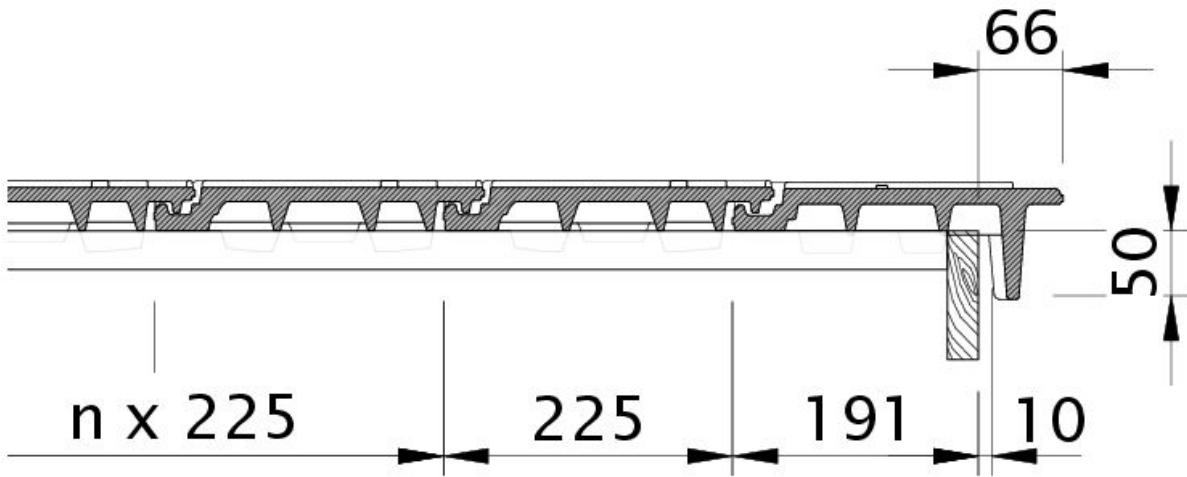

Tehnički crtež proizvoda DOMINO OBR OBR

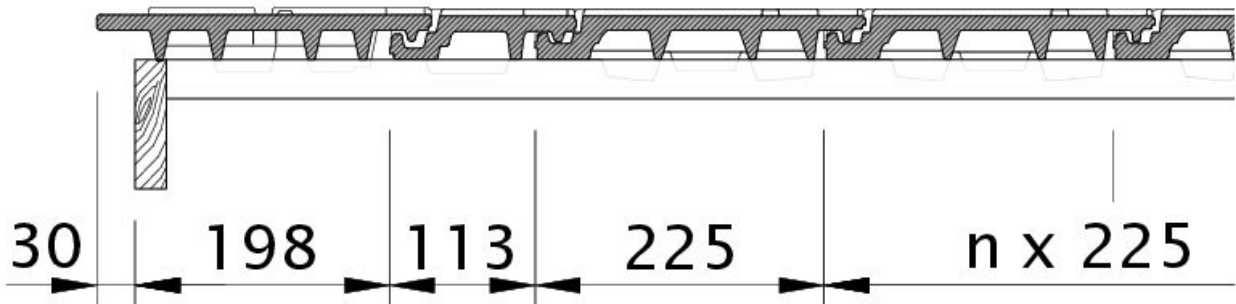

Tehnički crtež proizvoda DOMINO ODL ODL



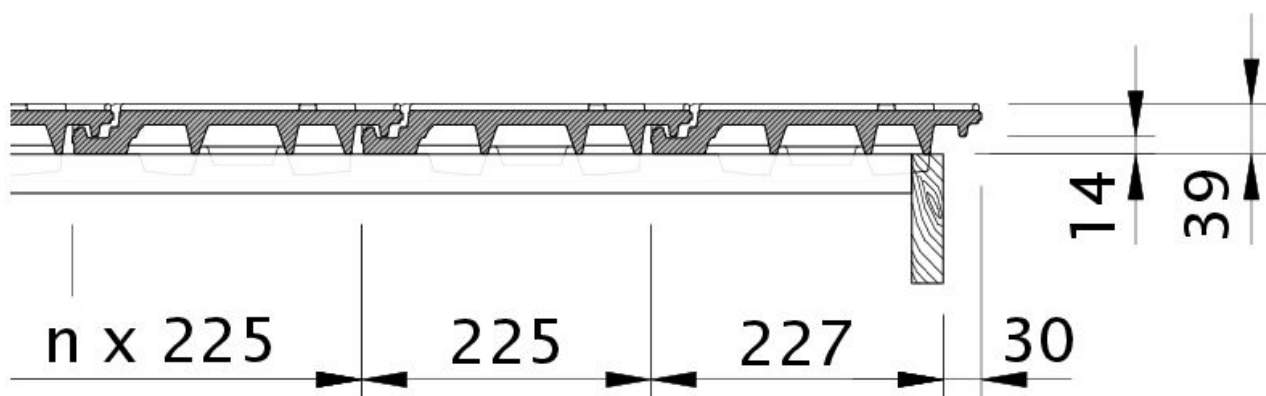

Tehnički crtež proizvoda DOMINO OG desni sa ivičnim limom i osnovnim crepom OFR

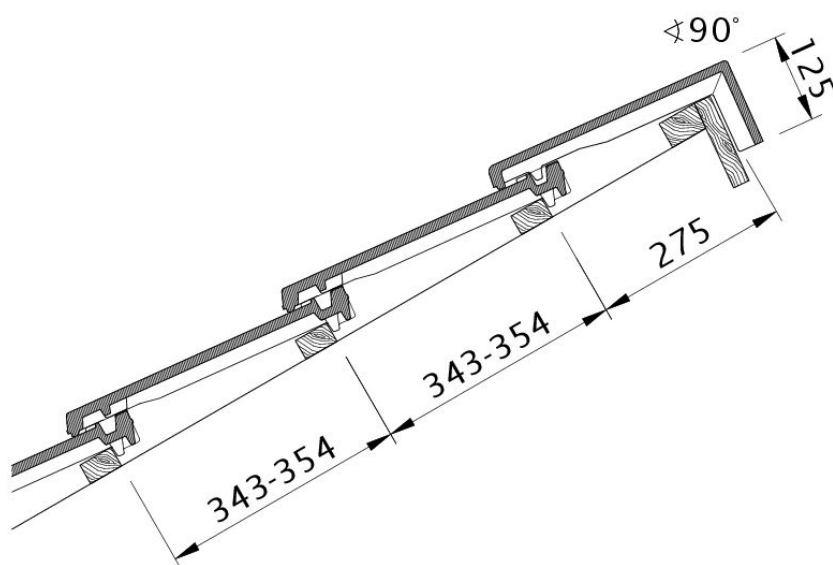

Tehnički crtež proizvoda DOMINO PDA PDA



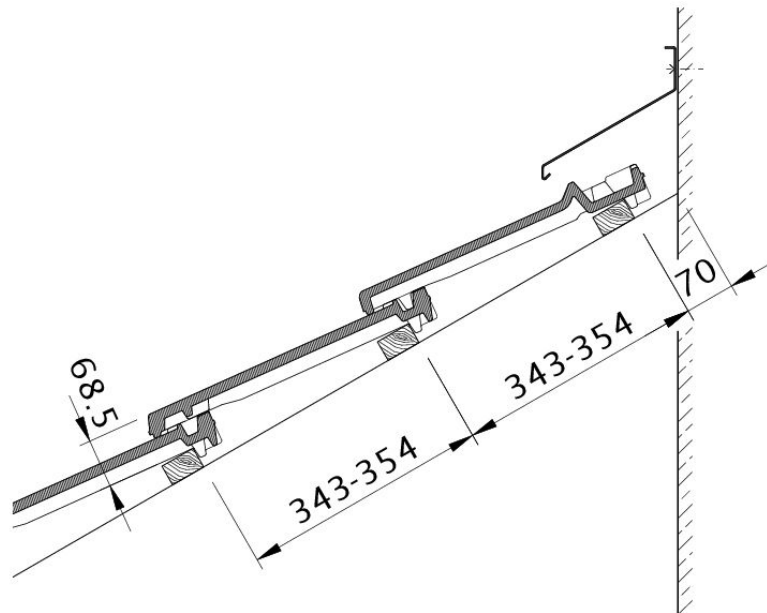

Tehnički crtež proizvoda DOMINO WMF WMF

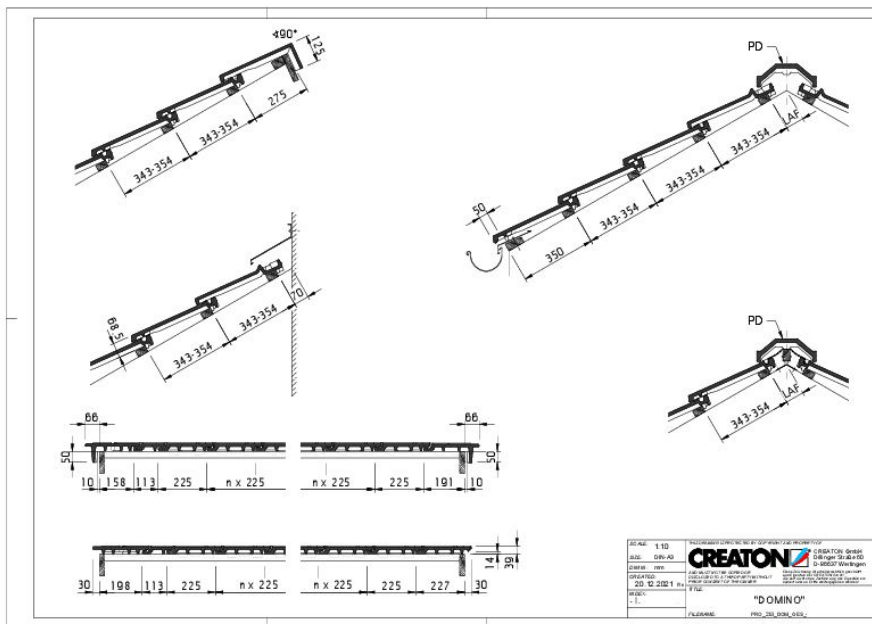

Drawing DOMINO general view GES



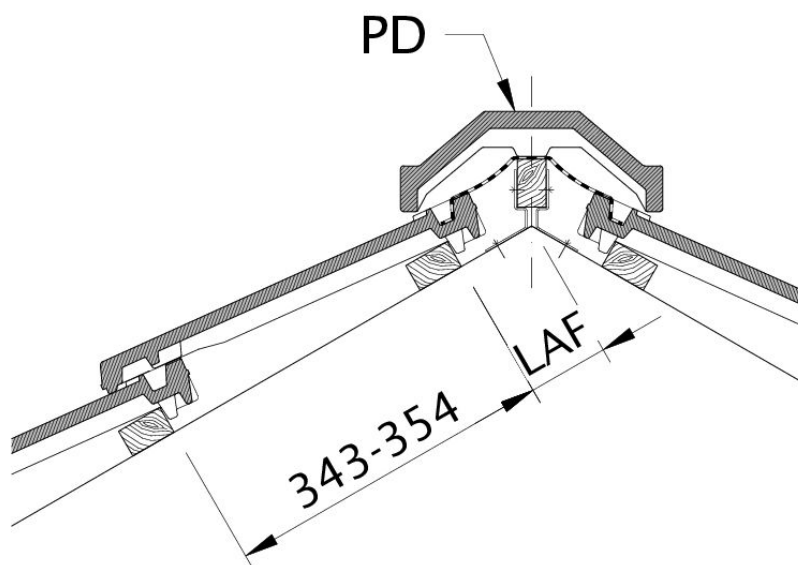

Tehnički crtež proizvoda DOMINO LAF LAF

